

**This electronic collection of documents is provided
for the convenience of the user
and is Not a Certified Document –**

**The documents contained herein were originally issued
and sealed by the individuals whose names and license
numbers appear on each page, on the dates appearing
with their signature on that page.**

**This file or an individual page
shall not be considered a certified document.**

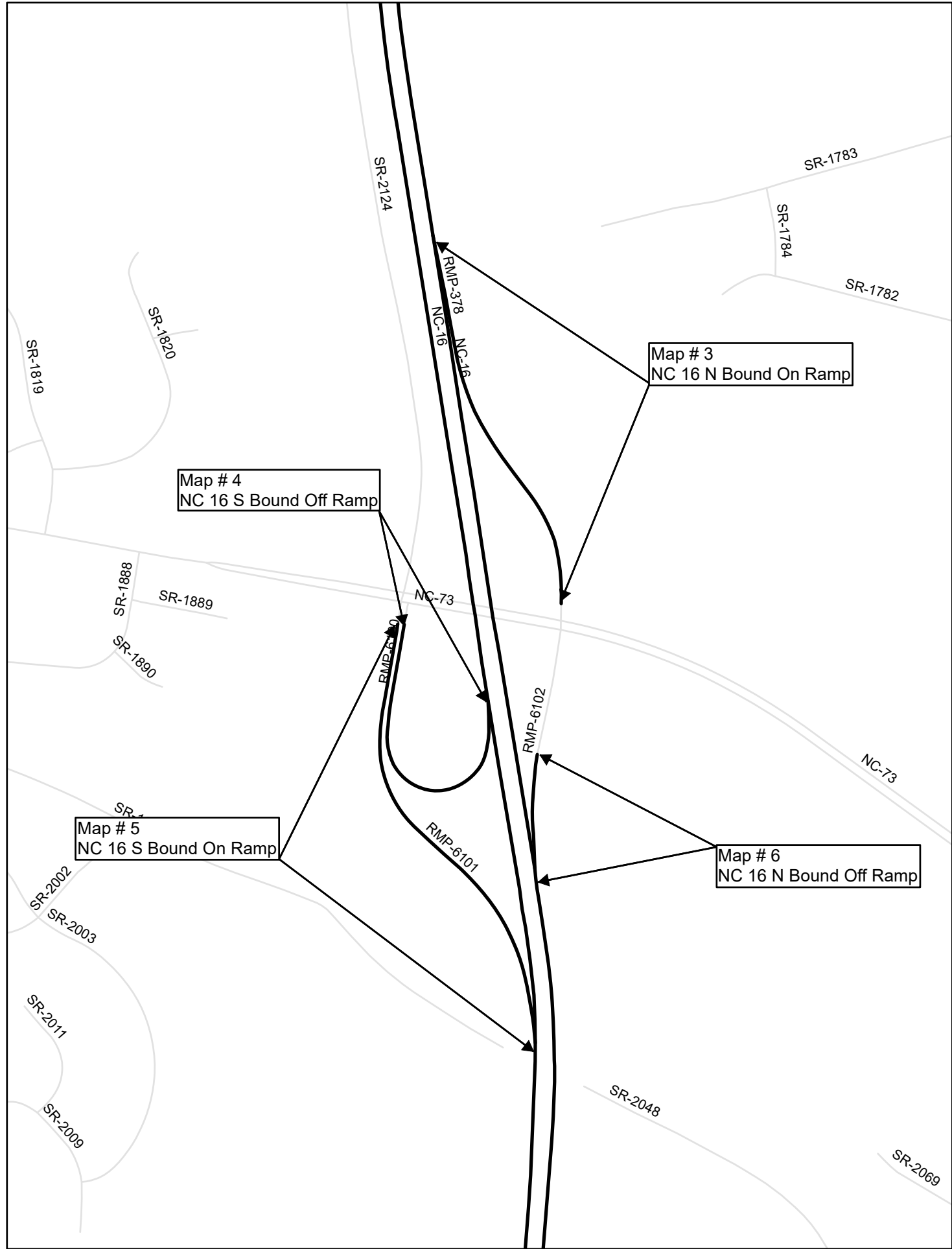

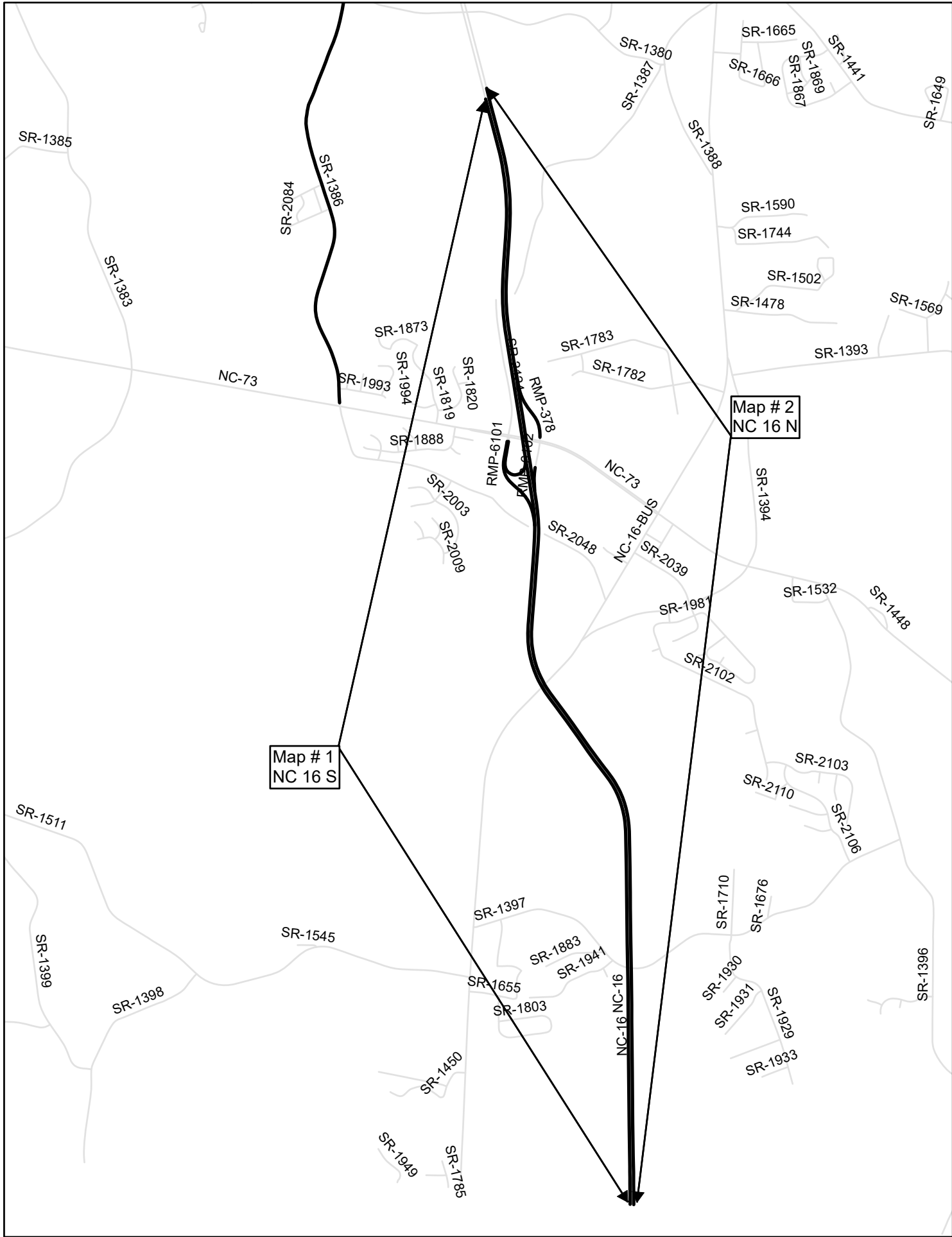
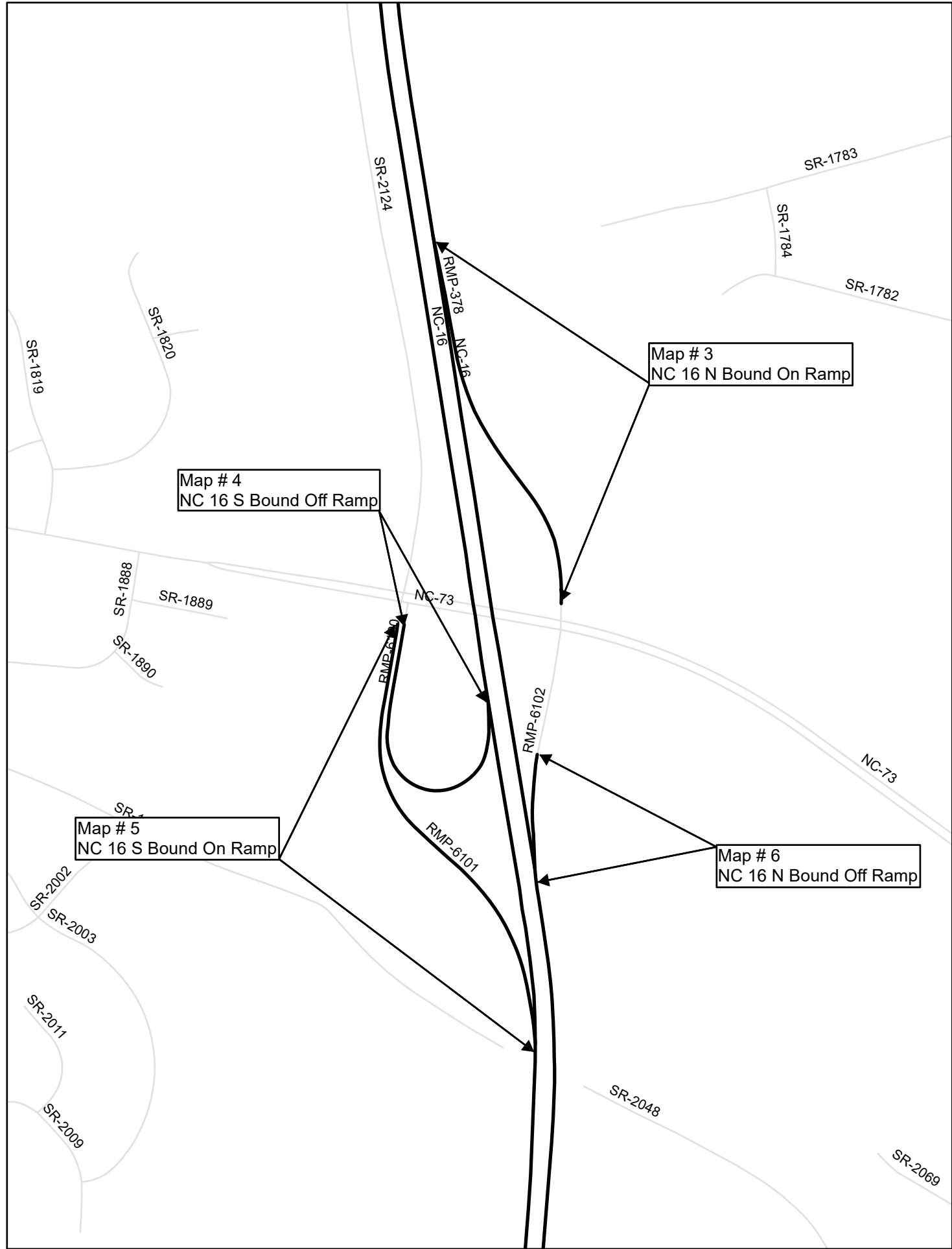
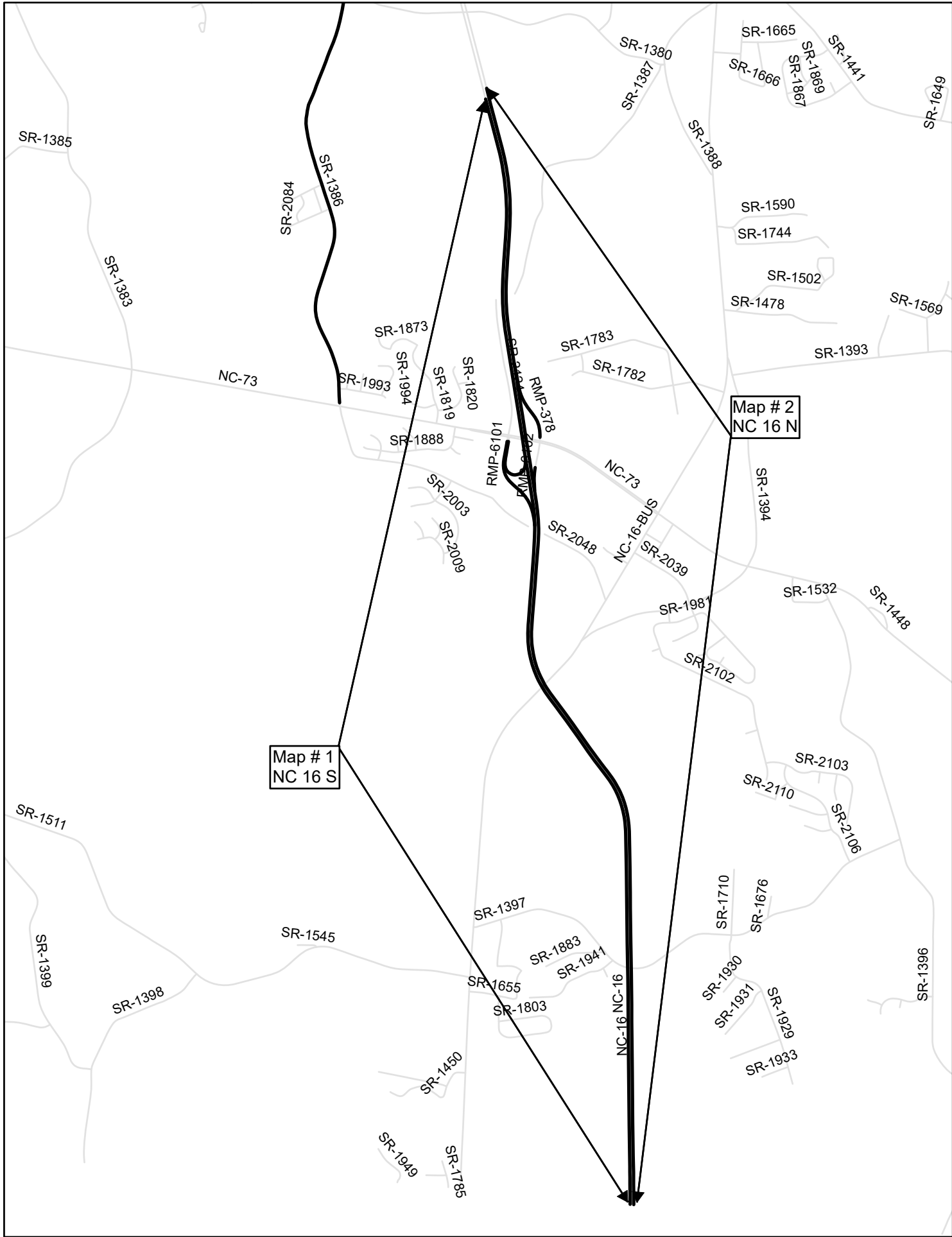
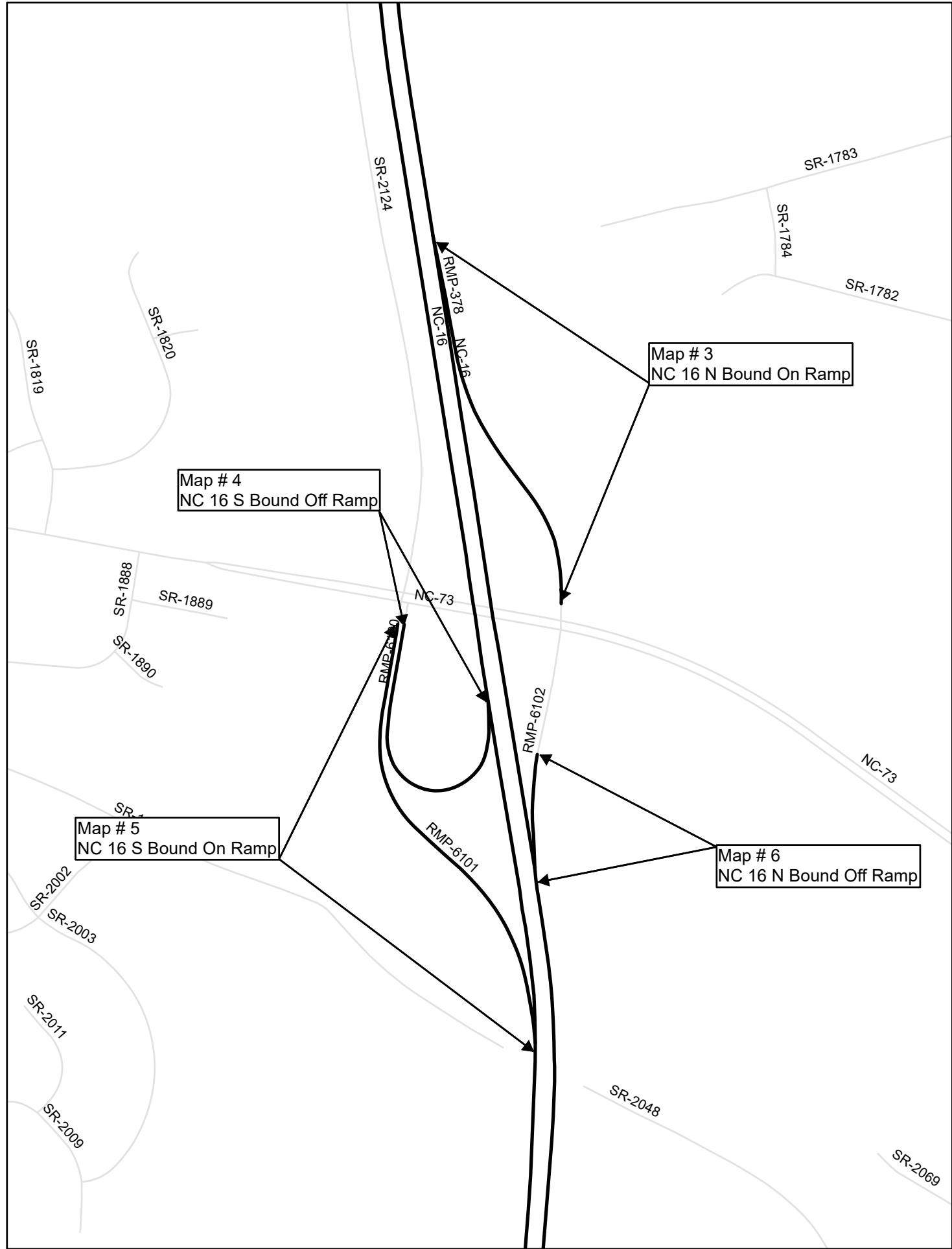
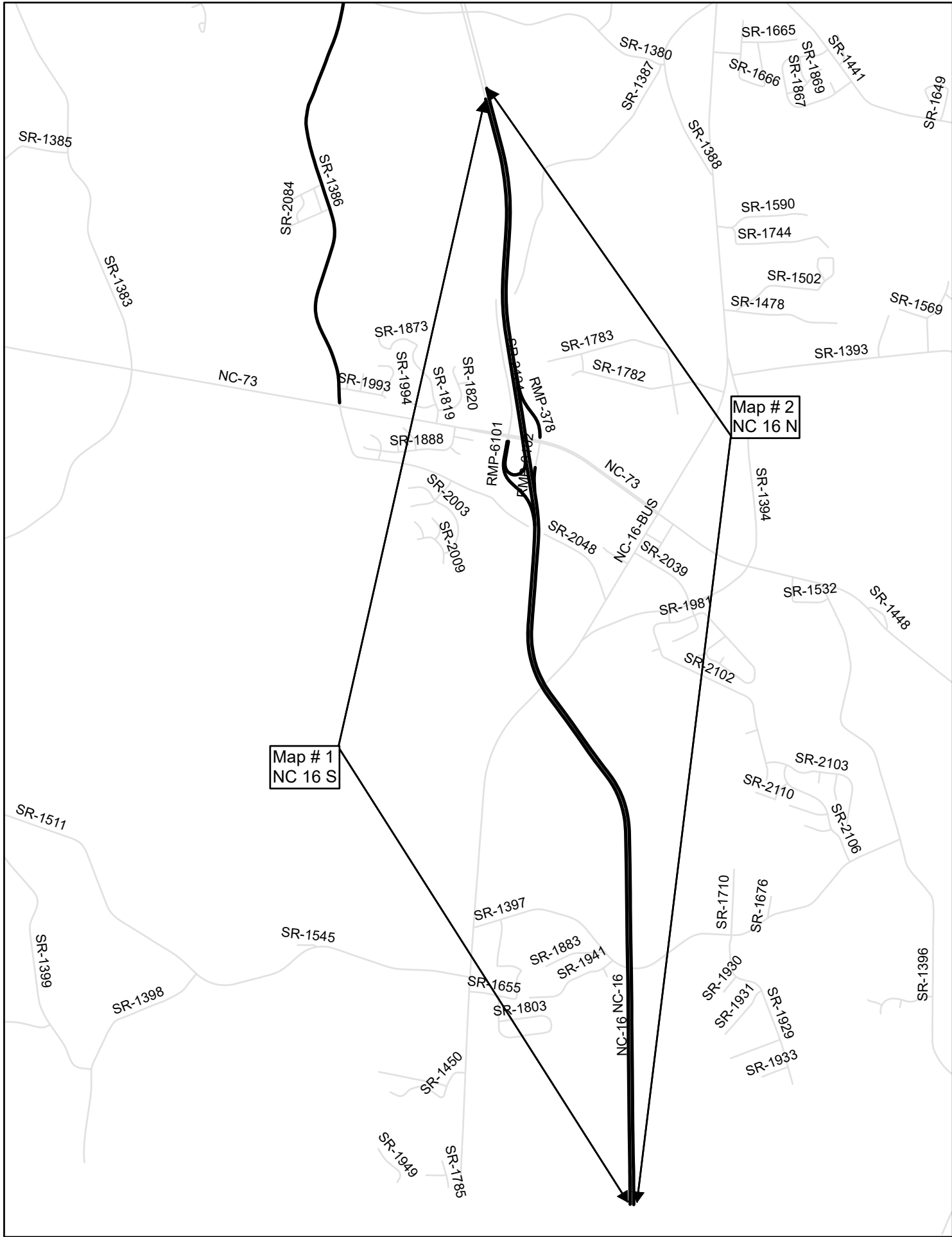
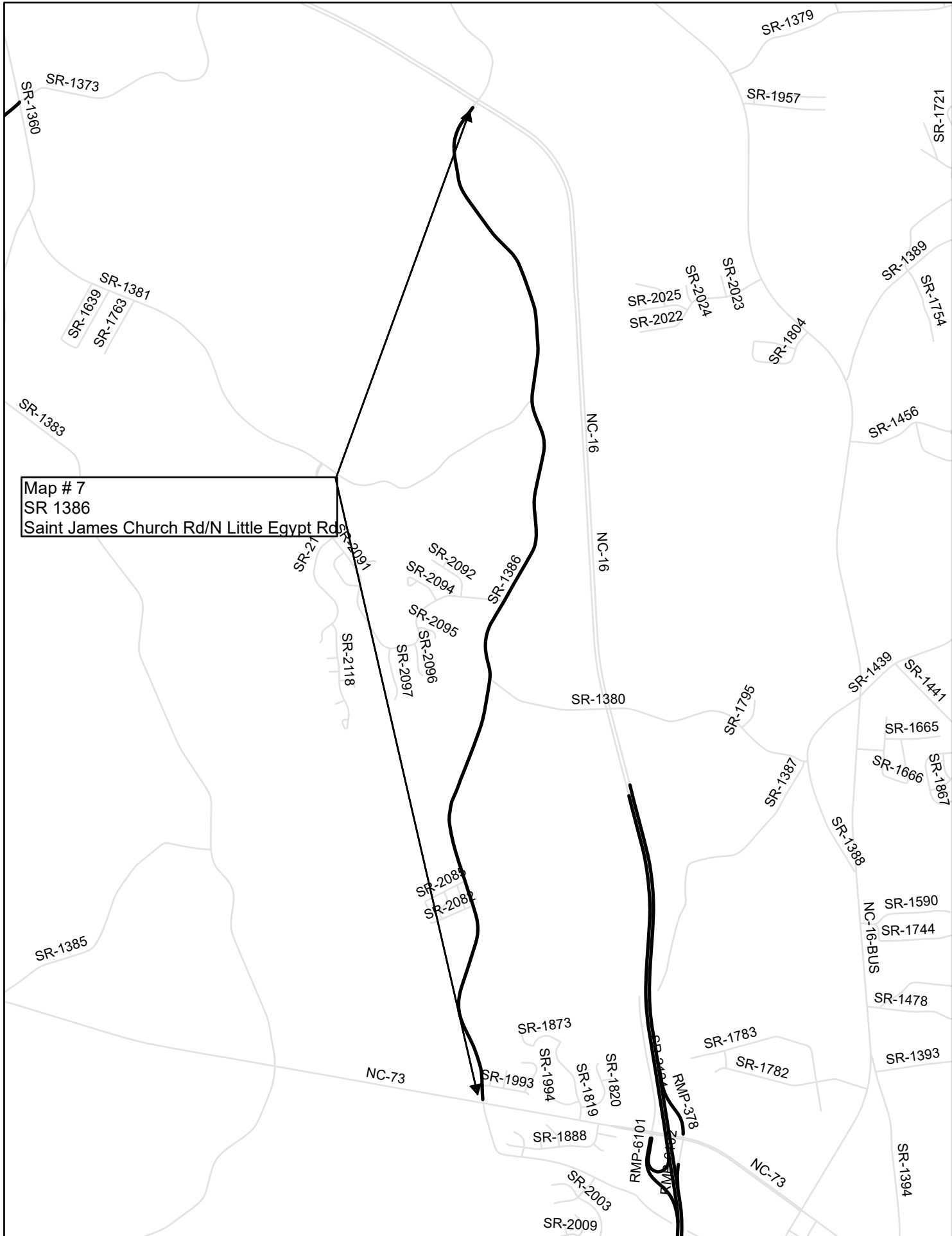

Map # 7
 SR 1386
 Saint James Church Rd/N Little Egypt Rd

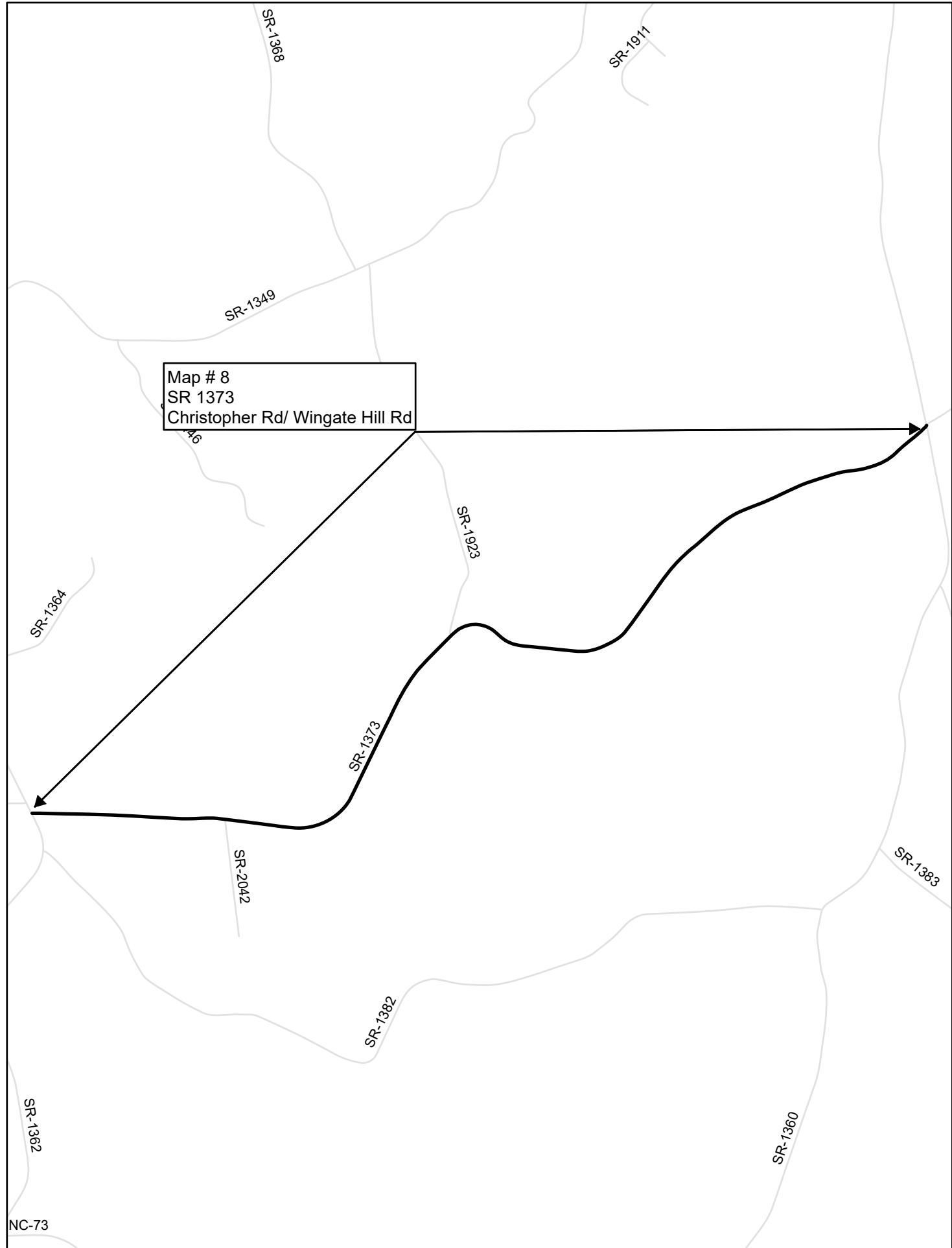

Map # 8
 SR 1373
 Christopher Rd/ Wingate Hill Rd



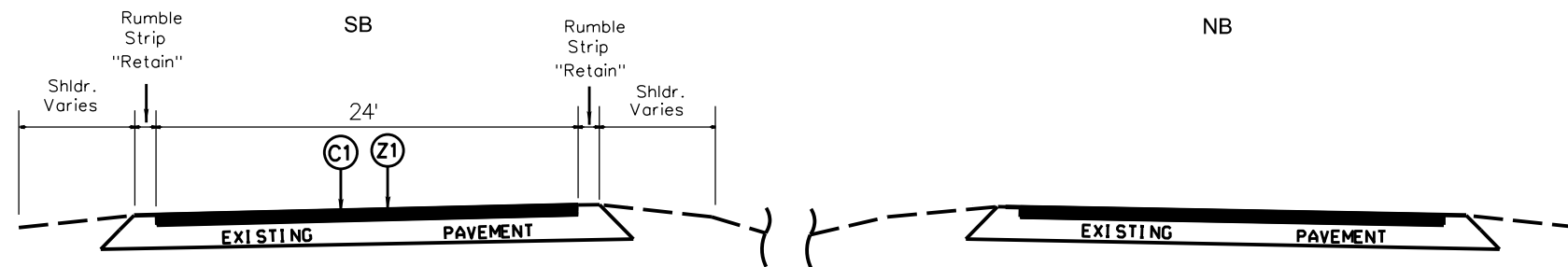

TYPICAL SECTION NO. 1

MAP # 1 - ENTIRE MAP

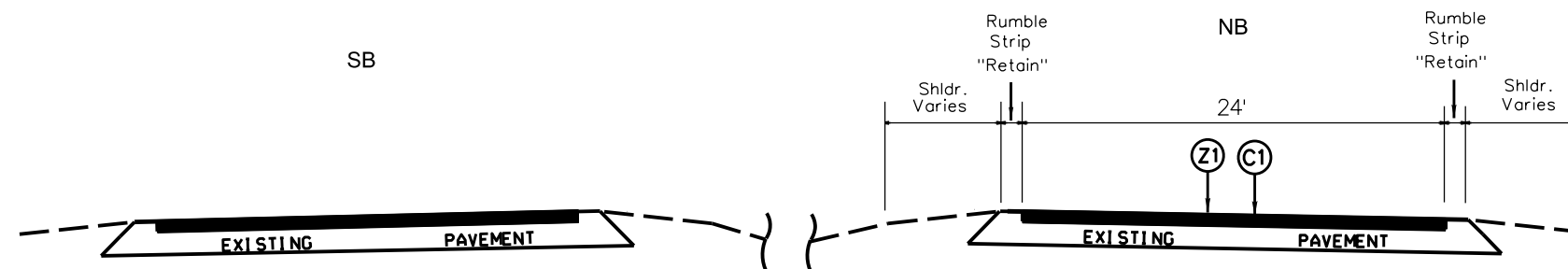

TYPICAL SECTION NO. 2

MAP # 2- ENTIRE MAP

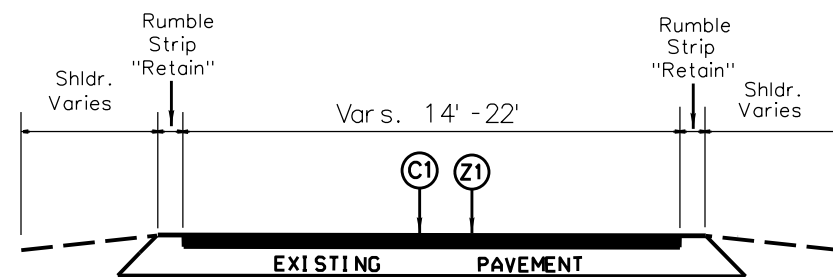

TYPICAL SECTION NO. 3

MAP # 3 - ENTIRE MAP
 MAP # 5 - ENTIRE MAP
 MAP # 6 - ENTIRE MAP

** Mill entire lane width beyond end of Rumble Strips unless otherwise directed by the Engineer.

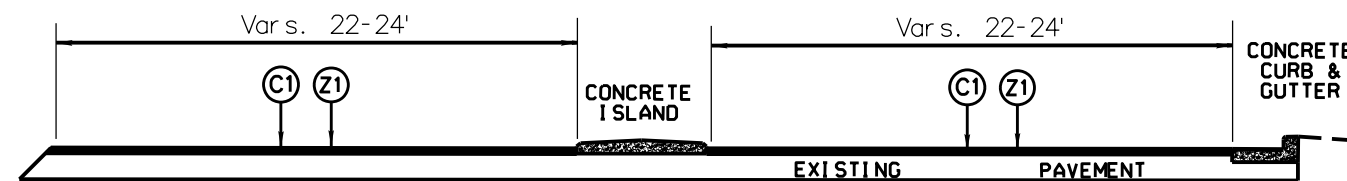

TYPICAL SECTION NO. 4

MAP # 4 - 8+00 to 12+85

PAVEMENT SCHEDULE	
C1	PROP. APPROX. 1½" ASPHALT CONCRETE SURFACE COURSE, TYPE S9.5C, AT AN AVERAGE RATE OF 168 LBS. PER SQ. YD.
Z1	MILL EXST. ASPHALT PAVMENT APPROX. 1 1/2" IN DEPTH
T	AGGREGATE SHOULDER BORROW (SHOULDER RECONSTRUCTION, WIDTH VARIES 2'-6')
Y1	INCIDENTAL MILLING

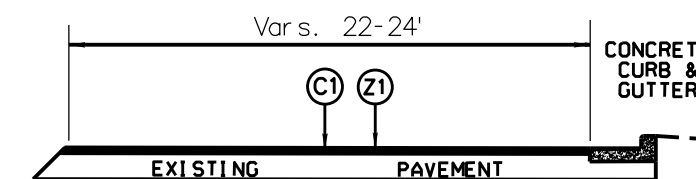

TYPICAL SECTION NO. 5

MAP # 4 - 0+00 to 8+00

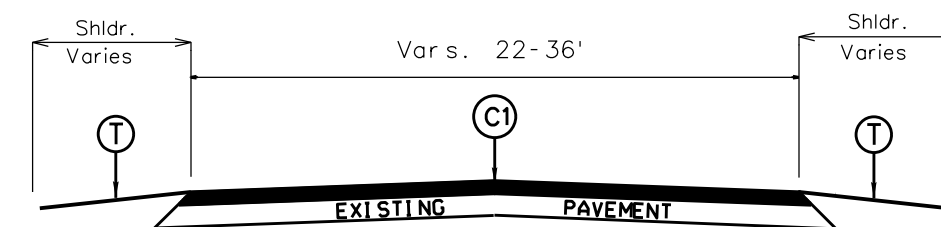

TYPICAL SECTION NO. 6

MAP 7 - ENTIRE MAP
 MAP 8 - ENTIRE MAP

**2026-2027
 Lincoln County Resurfacing**

Checked by: G. Brittain

STATE	PROJECT WBS	SHEET NUMBER
NC	2026CPT.12.06.10551	5
	2026CPT.12.06.20551	

DETAIL A
PATCHING EXISTING PAVEMENT

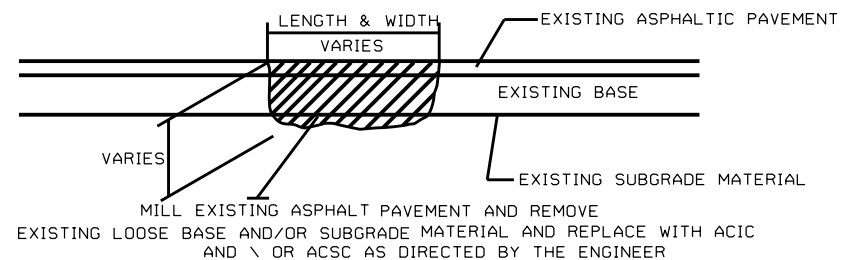

DETAIL D
MILLING BRIDGE APPROACHES



DETAIL B
ASPHALT CONCRETE SURFACE COURSE
TYPE S9.5C (LEVELING COURSE)

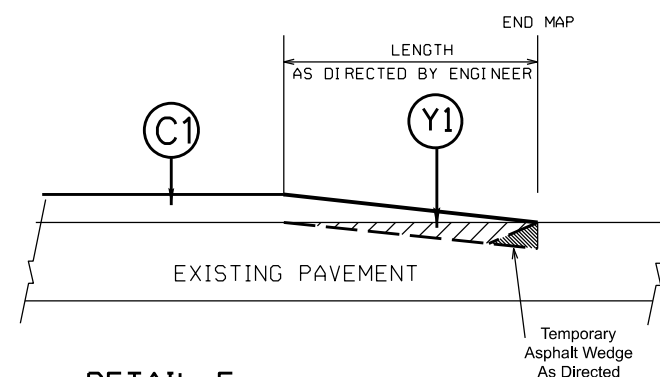
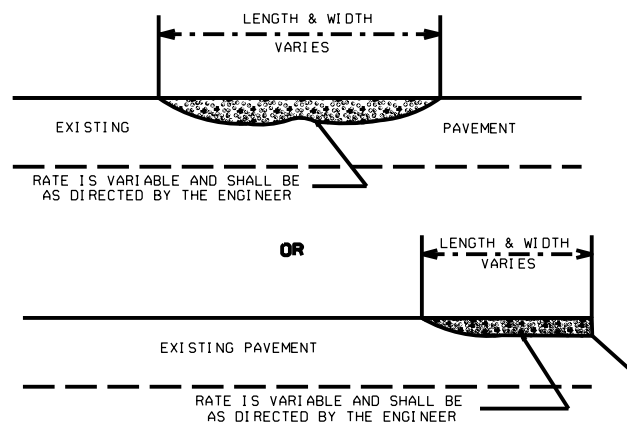

DETAIL E
TIE-IN (INCIDENTAL) MILLING DETAIL

DETAIL C
BRIDGE HALF TYPICAL SECTION

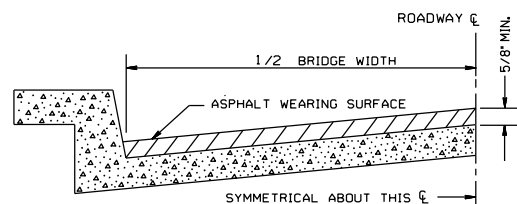

FOR BRIDGES WITH FLOOR DRAINS, CARE SHALL BE EXERCISED IN PLACING THE WEARING SURFACE AROUND FLOOR DRAINS SO AS NOT TO HINDER EFFECTIVE DRAINAGE. ALL DRAINS SHALL BE LEFT OPEN.

THE PROPOSED WEARING SURFACE SHALL VARY IN THICKNESS AS NECESSARY TO PROVIDE A SMOOTH RIDING SURFACE. A THICKNESS OF NOT LESS THAN 1" SHALL BE PROVIDED. THE MAXIMUM THICKNESS SHALL PREFERABLY BE 1-1/2" UNLESS IT IS IMPRACTICAL TO PROVIDE A SMOOTH RIDING SURFACE OTHERWISE.

NOTES

ALL UNPAVED S.R. ROADS TO BE SURFACED 50' FROM EDGE OF PAVEMENT OF MAIN PROJECT.

BRIDGES TO BE RESURFACED AT LOCATIONS AND TO DEPTH AS DIRECTED BY THE ENGINEER.

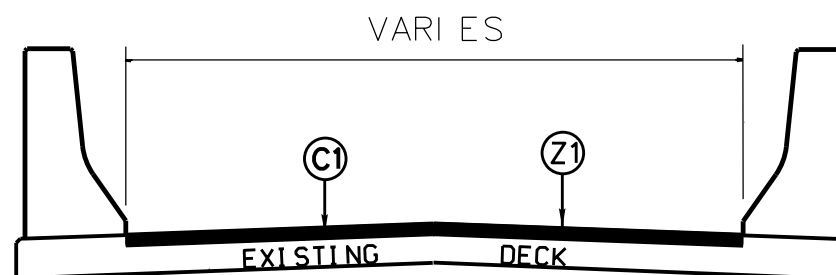

ASPHALT BRIDGE SECTION

Use for all asphalt bridges

PAVEMENT SCHEDULE	
C1	PROP. APPROX. 1 1/2" ASPHALT CONCRETE SURFACE COURSE, TYPE S9.5C, AT AN AVERAGE RATE OF 168 LBS. PER SQ. YD.
Z1	MILL EXST. ASPHALT PAVMENT APPROX. 1 1/2" IN DEPTH
T	AGGREGATE SHOULDER BORROW (SHOULDER RECONSTRUCTION, WIDTH VARIES 2'-6')
Y1	INCIDENTAL MILLING

2026-2027
Lincoln County Resurfacing

Checked by:

Drawn by: G. Brittain

- NOTES:
- 1) DETAIL DOES NOT APPLY TO OGAFc AND ULTRA-THIN BONDED WEARING COURSE.
 - 2) BACKFILL SHOULDER WITH APPROVED MATERIAL.
 - 3) THE SHOULDER WEDGE DEVICE MAY BE DISENGAGED AT PAVED DRIVEWAYS AND SIDE STREETS.

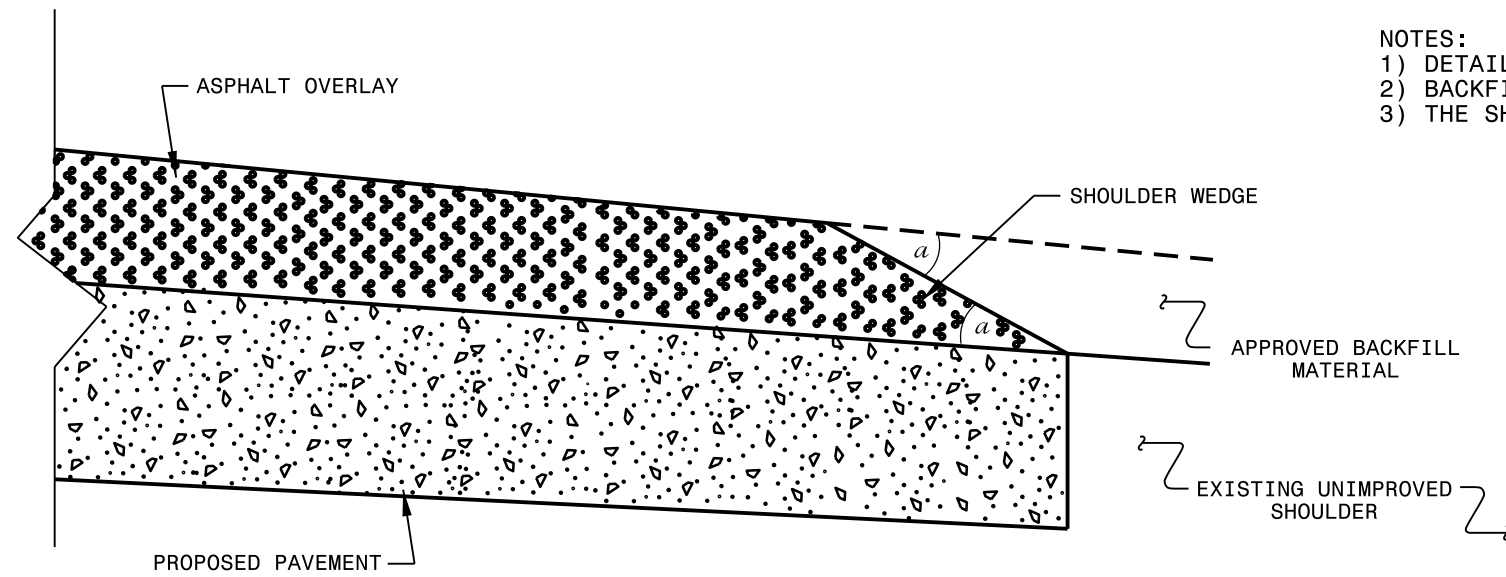

SHOULDER WEDGE DETAIL
(Resurfacing Projects w/ Widening or
with Existing Paved Shoulder having no dropoffs)

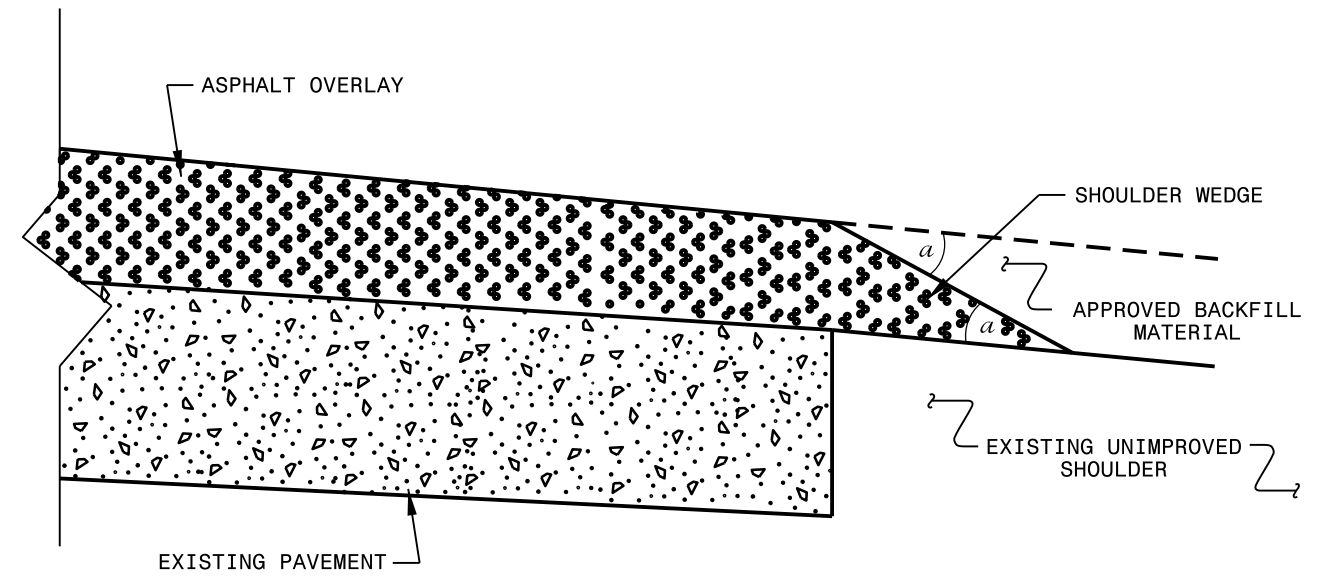

SHOULDER WEDGE DETAIL
(Resurfacing Projects w/ NO Widening)

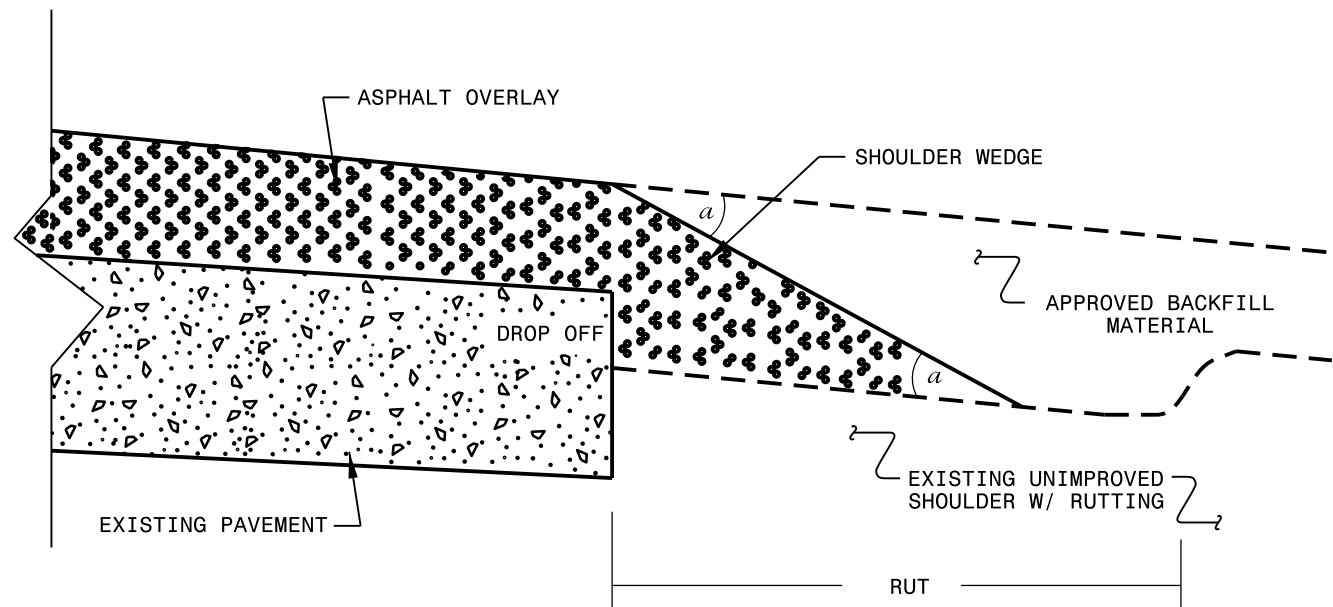

SHOULDER WEDGE DETAIL
(Resurfacing Adjacent to
Rutted Shoulder)

- SHOULDER WEDGE ANGLE = 30°

CONTRACT STANDARDS AND DEVELOPMENT UNIT			
Office 919-707-6950		FAX 919-250-4119	
SHOULDER WEDGE DETAILS			
ORIGINAL BY: T.SPELL	DATE: 7-19-11		
MODIFIED BY:	DATE: 10/16/12		
CHECKED BY:	DATE:		
FILE SPEC.: susr/details/stand/shoulderwedgedetail.dgn			

SYSTEMS DESIGN
USER NAME

PROJECT NO.	SHEET NO.	TOTAL NO.
2026CPT.12.0610551, 2026CPT.12.06.20551		

SUMMARY OF QUANTITIES

PROJECT NO	COUNTY	MAP NO	ROUTE	DESCRIPTION	TYP NO	LANES	LANE TYPE	LENGTH	WIDTH	BEGIN MP	END MP	1220000000-E	1245000000-E	1260000000-E	1297000000-E	1330000000-E	1521000000-E	1524000000-E	1575000000-E	1704000000-E	1840000000-E	2845000000-E	4600000000-N		5255000000-N	7444000000-E	74561000000-E			
												INCIDENTAL STONE BASE	SHOULDER RECONSTRUCTION	AGGREGATE SHOULDER BORROW	1½" MILLING	INCIDENTAL MILLING	ASPHALT CONC SURFACE COURSE, TYPE S9.5C	ASPHALT CONC SURFACE COURSE, TYPE S9.5C (LEVELING COURSE)	ASPHALT BINDER FOR PLANT MIX	PATCHING EXISTING PAVEMENT	MILLED RUMBLE STRIPS	ADJUSTMENT OF METER OR VALVE BOX	SINGLE LANE CLOSURE	RAMP/LOOP CLOSURE	PORTABLE LIGHTING	INDUCTIVE LOOP	LEAD-IN CABLE (14-2)			
								MI	FT			TONS	SMI	TON	SY	SY	TON	TON	TONS	TONS	LF	EA	EA	EA	EA	LS	LF	LF		
2026CPT.12.06.10551	Lincoln	1	NC-16 SB	FROM RR BRIDGE TO GASTON CO	1	2	MD	4.92	24	7.14	12.05					75,500	6,375	395	100	100		EA	EA	EA	EA	LS	LF	LF		
2026CPT.12.06.10551	Lincoln	2	NC-16 NB	FROM GASTON CO TO RR BRIDGE	2	2	MD	4.92	24	0	4.92					75,500	6,375	395	100	100		EA	EA	EA	EA	LS	LF	LF		
2026CPT.12.06.10551	Lincoln	3	NC 16 N BOUND ON RAMP	FROM NC 73 TO NC 16 N	3	2	MD	0.35	14-22	0.02	0.37					2,875	275	17				EA	EA	EA	EA	LS	LF	LF		
2026CPT.12.06.10551	Lincoln	4	NC 16 S BOUND OFF LOOP	FROM NC 16 S TO NC 73	4,5	2	MD	0.28	14-24	0	0.28					2,300	350	22				EA	EA	EA	EA	LS	LF	LF		
2026CPT.12.06.10551	Lincoln	5	NC 16 S BOUND ON RAMP	FROM NC 73 TO NC 16 S	3	2	MD	0.23	14-22	0.2	0.43					1,889	300	19				EA	EA	EA	EA	LS	LF	LF		
2026CPT.12.06.10551	Lincoln	6	NC 16 N BOUND OFF RAMP	FROM NC 16 N TO NC 73	3	2	MD	0.1	14-22	0	0.1					821	100	6				EA	EA	EA	EA	LS	LF	LF		
TOTAL FOR PROJ NO. 2026CPT.12.0610551								10.8								158,885		13,775		854	200	200		24	4	1	300	25		
2026CPT.12.06.20551	Lincoln	7	SR-1386 / SAINT JAMES CHURCH RD/N LITTLE EGYPT RD	FROM NC 16 TO NC 73	6	2	2WU	4.55	22-36	1.78	6.33	60	9.10	910		2,125	5,670	347	250			EA	EA	EA	EA	LS	LF	LF		
2026CPT.12.06.20551	Lincoln	8	SR-1373 / CHRISTOPHER RD/WINGATE HILL RD	FROM SR 1362 (AMITY CH RD) TO SR 1360 (BETH HAVEN CH RD)	6	2	2WU	3.16	22	4.45	7.61	40	6.32	632	1,792	800	3,618	2,407	367	250		EA	EA	EA	EA	LS	LF	LF		
TOTAL FOR PROJ NO. 2026CPT.12.06.20551								7.71						100	15.42	1,542	1,792	2,925	9,288	2,407	714	500		2						
GRAND TOTAL								18.51					100	15.42	1,542	160,677	2,925	23,063	2,407	1,568	700	200	2	24	4	1	300	25		

PROJECT NO.	SHEET NO.	TOTAL NO.
2026CPT.12.0610551,		
2026CPT.12.06.20551		

THERMOPLASTIC AND PAINT QUANTITIES

PROJECT NO	COUNTY	MAP NO	ROUTE	DESCRIPTION	TYP NO	LANES	LANE TYPE	LENGTH	WIDTH	BEGIN MP	END MP	4400000000-E	4413000000-E	4423000000-N	4424000000-N	4434000000-N	4457000000-N	4510000000-N	4685000000-E		4688000000-E		4700000000-E		4709000000-E		
												STATIONARY WORK ZONE SIGNS	WORK ZONE ADVANCE GENERAL WARNING	WORK ZONE DIGITAL SPEED LIMIT SIGNS	WORK ZONE PRESENCE LIGHTING	SEQUENTIAL FLASHING WARNING LIGHTS	TEMP TRAFFIC CONTROL	LAW ENFORCEMENT	4" X 90 M WHITE THERMO	4" X 90 M YELLOW THERMO	6" X 90 M WHITE THERMO	6" X 90 M YELLOW THERMO	12" X 90 M WHITE THERMO	12" X 90 M YELLOW THERMO	24" X 90 MILS WHITE THERMO		
								MI	FT			SF	SF	EA	EA	EA	LS	HR	LF	LF	LF	LF	LF	LF	LF		
2026CPT.12.06.10551	Lincoln	1	NC-16 SB	FROM RR BRIDGE TO GASTON CO	1	2	MD	4.92	24	7.14	12.05	416		4	13	12		250			32,000	26,000	1,500				
2026CPT.12.06.10551	Lincoln	2	NC-16 NB	FROM GASTON CO TO RR BRIDGE	2	2	MD	4.92	24	0	4.92	416		4	13	12		250			32,000	26,000	875				
2026CPT.12.06.10551	Lincoln	3	NC 16 N BOUND ON RAMP	FROM NC 73 TO NC 16 N	3	2	MD	0.35	14-22	0.02	0.37																
2026CPT.12.06.10551	Lincoln	4	NC 16 S BOUND OFF LOOP	FROM NC 16 S TO NC 73	4,5	2	MD	0.28	14-24	0	0.28								200								
2026CPT.12.06.10551	Lincoln	5	NC 16 S BOUND ON RAMP	FROM NC 73 TO NC 16 S	3	2	MD	0.23	14-22	0.2	0.43																
2026CPT.12.06.10551	Lincoln	6	NC 16 N BOUND OFF RAMP	FROM NC 16 N TO NC 73	3	2	MD	0.1	14-22	0	0.1																
TOTAL FOR PROJ NO. 2026CPT.12.0610551								10.8				832		8	26	24		500		200	64,000	52,000	2,375				
																				200							
2026CPT.12.06.20551	Lincoln	7	SR-1386 / SAINT JAMES CHURCH RD/N LITTLE EGYPT RD	FROM NC 16 TO NC 73	6	2	2WU	4.55	22	1.78	6.33		290							48,200	51,000			150	176		
2026CPT.12.06.20551	Lincoln	8	SR-1373 / CHRISTOPHER RD/WINGATE HILL RD	FROM SR 1362 (AMITY CH RD) TO SR 1360 (BETH HAVEN CH RD)	6	2	2WU	3.16	22	4.45	7.61		250				*							26			
TOTAL FOR PROJ NO. 2026CPT.12.06.20551								7.71				540									48,200	51,000			150	202	
																				99,200							
GRAND TOTAL								18.51				832	540	8	26	24		1	500		48,400	51,000	64,000	52,000	2,375	150	202
																				99,400	116,000			2,525			

PROJECT NO	COUNTY	MAP NO	ROUTE	DESCRIPTION	TYP NO	LANES	LANE TYPE	LENGTH	WIDTH	BEGIN MP	END MP	4720000000-E	4725000000-E				4810000000-E		4870000000-E	4875000000-N	4905100000-N			
												THERMO MSG SCHOOL 90 M	THERMO LT ARROW 90 M	THERMO STR ARROW 90 M	THERMO RT ARROW 90 M	THERMO STR & RT ARROW 90 M	4" WHITE PAINT	4" YELLOW PAINT	24" LINE REMOVAL	REMOVAL OF PAVEMENT MARKING SYMBOLS & CHARACTERS	POLYCARBONATE H-SHAPED PAVEMENT MARKERS			
								MI	FT			EA	EA	EA	EA	EA	LF	LF	LF	EA	EA			
2026CPT.12.06.10551	Lincoln	1	NC-16 SB	FROM RR BRIDGE TO GASTON CO	1	2	MD	4.92	24	7.14	12.05									3	400			
2026CPT.12.06.10551	Lincoln	2	NC-16 NB	FROM GASTON CO TO RR BRIDGE	2	2	MD	4.92	24	0	4.92									3	425			
2026CPT.12.06.10551	Lincoln	3	NC 16 N BOUND ON RAMP	FROM NC 73 TO NC 16 N	3	2	MD	0.35	14-22	0.02	0.37													
2026CPT.12.06.10551	Lincoln	4	NC 16 S BOUND OFF LOOP	FROM NC 16 S TO NC 73	4,5	2	MD	0.28	14-24	0	0.28		3		3					6	10			
2026CPT.12.06.10551	Lincoln	5	NC 16 S BOUND ON RAMP	FROM NC 73 TO NC 16 S	3	2	MD	0.23	14-22	0.2	0.43													
2026CPT.12.06.10551	Lincoln	6	NC 16 N BOUND OFF RAMP	FROM NC 16 N TO NC 73	3	2	MD	0.1	14-22	0	0.1													
TOTAL FOR PROJ NO. 2026CPT.12.0610551								10.8					3	6	3							12	835	
2026CPT.12.06.20551	Lincoln	7	SR-1386 / SAINT JAMES CHURCH RD/N LITTLE EGYPT RD	FROM NC 16 TO NC 73	6	2	2WU	4.55	22-36	1.78	6.33	24	4		1	2				176	31	325		
2026CPT.12.06.20551	Lincoln	8	SR-1373 / CHRISTOPHER RD/WINGATE HILL RD	FROM SR 1362 (AMITY CH RD) TO SR 1360 (BETH HAVEN CH RD)	6	2	2WU	3.16	22	4.45	7.61	24	4		1	2				67,000	67,000	202	31	325
TOTAL FOR PROJ NO. 2026CPT.12.06.20551								7.71					7								134,000			
GRAND TOTAL								18.51				24	7	6	4	2				67,000	67,000	202	43	1,160
																				19	134,000			

SIGNING FOR RESURFACING PROJECTS

LEGEND

┆ STATIONARY SIGN

← DIRECTION OF TRAFFIC FLOW

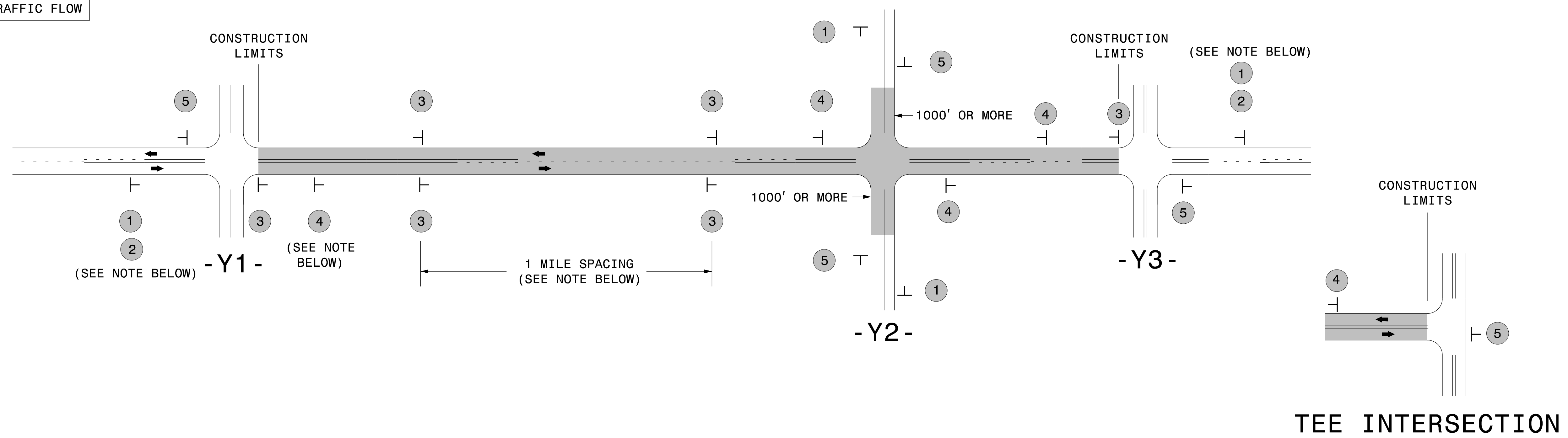

MAINLINE (-L-) SIGNING

-Y- LINE SIGNING

SIGNING NOTES AND PLACEMENT PER DIRECTION	1		PLACE 1000' PRIOR TO BEGINNING OF CONSTRUCTION LIMITS. ONLY USED ON -Y- LINES IF RESURFACING LIMITS EXTEND 1000' ALONG -Y- LINE.	<p>NO REQUIRED STATIONARY SIGNING FOR THE FOLLOWING -Y- LINE CONDITIONS:</p> <ol style="list-style-type: none"> 1) LESS THAN 1000' OF RESURFACING ALONG -Y- LINE 2) SUBDIVISION ROADS 3) DEAD END ROADS <p>WHEN PAVING/CONSTRUCTION ACTIVITIES PROCEED ACROSS AN UNSIGNED -Y- LINE, PORTABLE ADVANCE WARNING SIGNS SHALL BE USED ALONG THE -Y- LINE AS SHOWN BELOW. REMOVE UPON COMPLETION OF WORK.</p> <div style="display: flex; justify-content: space-around;"> <div style="text-align: center;"> W20-1 48" X 48" PLACED 500' IN ADVANCE OF FLAGGER. </div> <div style="text-align: center;"> W20-7 A 48" X 48" PLACED 250' IN ADVANCE OF FLAGGER. </div> </div>
	2		#2 SIGN ONLY USED WHEN CONSTRUCTION LIMITS ARE 2 OR MORE MILES IN LENGTH. ROUND UP TO NEXT WHOLE NUMBER. (NO FRACTIONAL OR DECIMAL NUMBERS)	
	3		- PLACE INITIALLY AT THE CONSTRUCTION LIMITS AND SPACE 1 MILE APART THEREAFTER. - AT TEE INTERSECTIONS INSTALL INITIALLY 1/2 MILE FROM INTERSECTION AND SPACE 1 MILE APART THEREAFTER.	
	4		- THESE ARE FOR -Y- LINES THAT ARE "THROUGH" ROADWAYS. - DEAD END AND SUBDIVISION ROADS ARE NOT "THROUGH" ROADWAYS. - INSTALL 500' +/- FROM EACH -Y- LINE APPROACH AS SHOWN ABOVE. - FOR MULTIPLE -Y- LINES THAT ARE SEPARATED BY 0.25 MILES OR LESS, TREAT AS A SINGLE UNIT AND INSTALL WITHIN 500' OF EACH APPROACH. - A MAXIMUM OF 2 SIGN SETS PER MILE. DO NOT INSTALL WHEN -Y- LINES ARE WITHIN 0.5 MILES FROM "END ROAD WORK" SIGN. - FOR TEE INTERSECTIONS, INSTALL WITHIN 500' +/- OF THE INTERSECTION ALONG -L- LINE.	
	5		PLACE 500' FOLLOWING THE END OF CONSTRUCTION LIMITS OR AS SHOWN WHEN WORK ENDS AT A 3-WAY TEE INTERSECTION.	

THE ABOVE SIGNS ARE ALL THAT ARE REQUIRED FOR A CONTRACTOR TO BEGIN A RESURFACING CONTRACT. ANY ADDITIONAL SIGNS REQUESTED BY NCDOT DIVISIONS SHALL BE INSTALLED WITHIN 7 BUSINESS DAYS OF THE START OF CONTRACT WORK.

MAPS LESS THAN 2 MILES

FOR RESURFACING MAPS WITH CONSTRUCTION LIMITS LESS THAN 2 MILES IN LENGTH, NO STATIONARY SIGNS ARE REQUIRED. USE PORTABLE "ROAD UNDER CONSTRUCTION" OR "ROAD WORK AHEAD" SIGNS IN LIEU OF STATIONARY ADVANCE WARNINGS SIGNS.

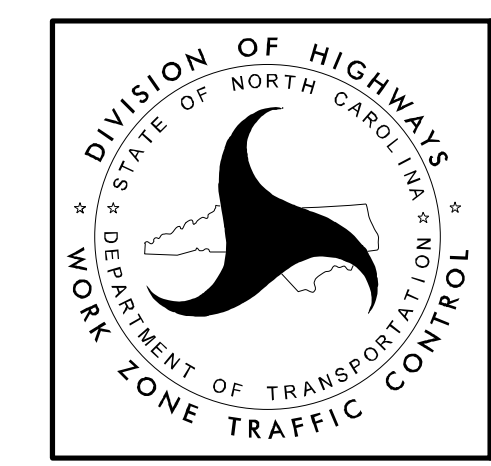

ADVANCE WARNING SIGNS FOR RURAL AND SUBURBAN 2-LANE ROADWAY RESURFACING

DIVIDED MEDIANS WITH WIDTHS 46' OR GREATER

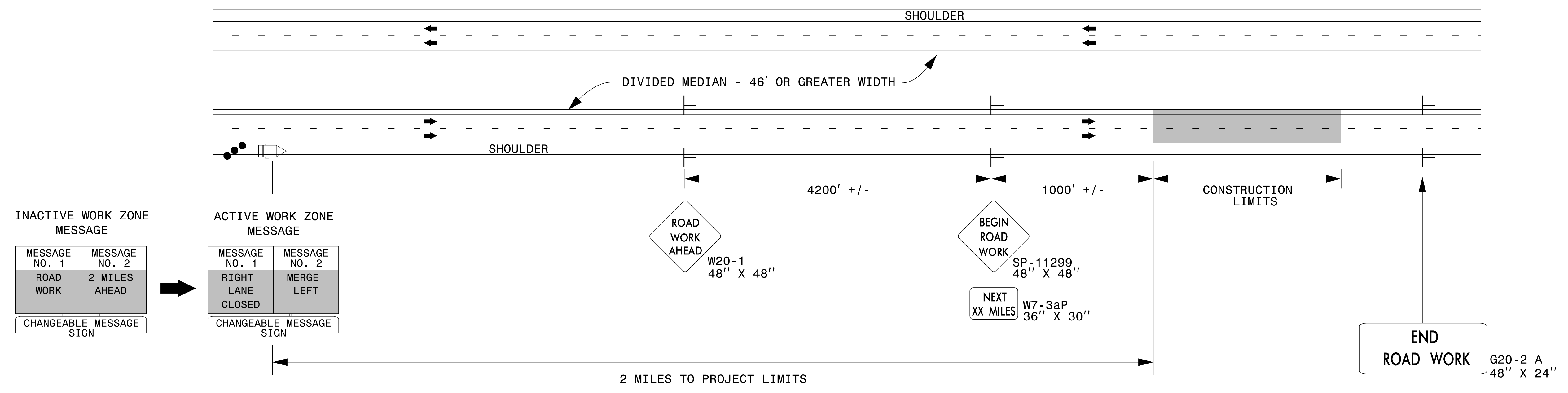

DIVIDED MEDIANS WITH WIDTHS LESS THAN 46' OR WITH PERMANENT MEDIAN BARRIER

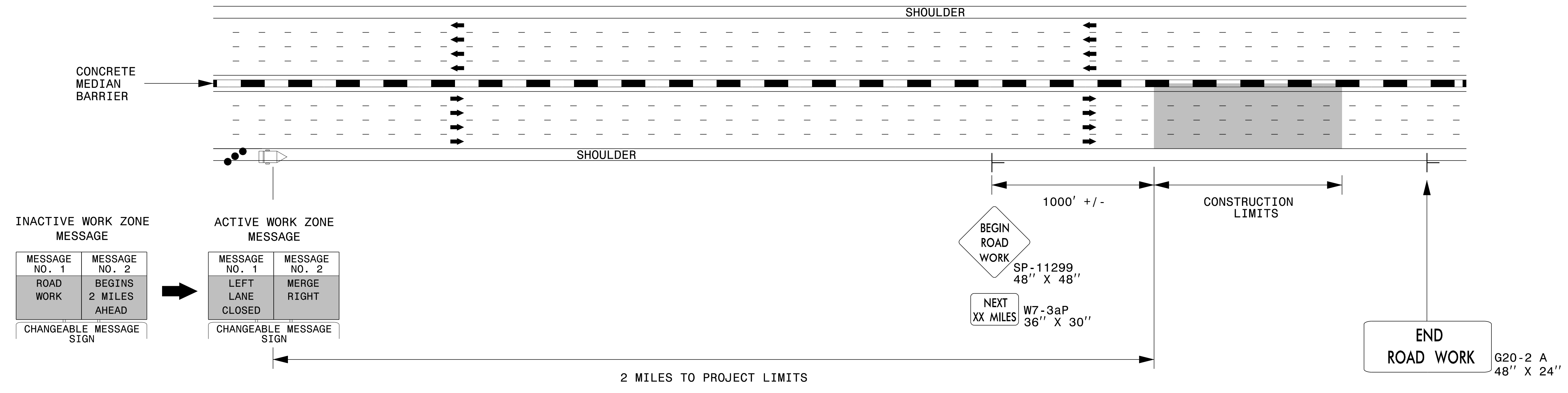

NOTES:

- 1) LATERAL CLEARANCE AT ALL SIGN LOCATIONS SHALL BE 6' AS MEASURED FROM THE EDGE OF PAVEMENT.
- 2) MOUNT SIGNS THAT ARE LARGER THAN 10 SQUARE FEET IN AREA ON TWO OR MORE WOOD OR U-CHANNEL SUPPORTS. PERFORATED SQUARE TUBING SUPPORT SYSTEMS MAY SUPPORT LARGER AREAS ON A SINGLE SUPPORT. FOLLOW MANUFACTURER'S RECOMMENDATIONS. THESE SYSTEMS SHALL BE NCHRP 350 COMPLIANT AND NCDOT APPROVED.
- 3) FOR MEDIAN WIDTHS LESS THAN 46' (MEASURED EDGELINE TO EDGELINE) USE THE BOTTOM DRAWING.
- 4) IF STATIONARY GENERAL WARNING SIGNS ARE USED, THEY WILL BE PAID FOR PER SECTION 104 OF THE NCDOT STANDARD SPECIFICATIONS AS EXTRA WORK.
- 5) INSTALL "ROAD WORK AHEAD" (W20-1) ALONG ENTRANCE RAMP 500' PRIOR TO RAMP TERMINAL, AND "END ROAD WORK" (G20-2a) AT THE END OF EXIT RAMP WITHIN THE WORK ZONE.
- 6) IF MILLED AREAS ARE NOT PAVED BACK BY THE END OF THE WORK DAY, PORTABLE SIGNS SHALL BE USED TO WARN DRIVERS OF THE PRESENT CONDITIONS. THESE ARE TO INCLUDE, BUT NOT LIMITED TO "ROUGH ROAD" W8-8, "UNEVEN LANES" W8-11, "GROOVED PAVEMENT" W8-15 w/MOTORCYCLE PLAQUE MOUNTED BELOW. THESE ARE TO BE DOUBLE INDICATED ON MULTI-LANE ROADWAYS WITH SPEED LIMITS 45 MPH AND GREATER AND WITH DIVIDED MEDIANS OF 46' OR GREATER. THESE PORTABLE SIGNS ARE INCIDENTAL TO THE OTHER ITEMS OF WORK INCLUDED IN THE TEMPORARY TRAFFIC CONTROL (LUMP SUM) PAY ITEM.

LEGEND

- CHANGEABLE MESSAGE SIGN (CMS)
- STATIONARY SIGN
- DIRECTION OF TRAFFIC FLOW
- TRAFFIC DRUM

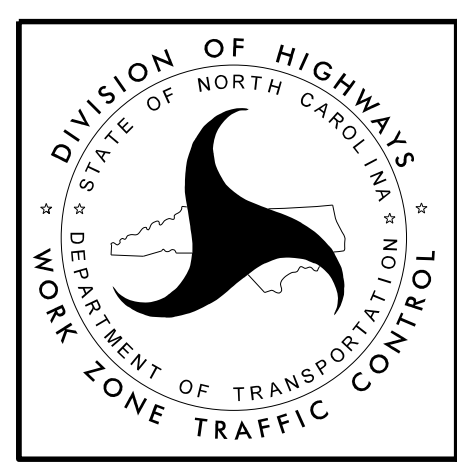

**RESURFACING ADVANCE
WARNING SIGNS FOR
HIGH SPEED FACILITIES
≥ 60 MPH**

3/23/2015 C:\Users\rmgarrrett\Downloads\Resurfacing_AdvWarn_HSpd.dgn User:rmgarrrett

High Speed Detection (≥40 mph)

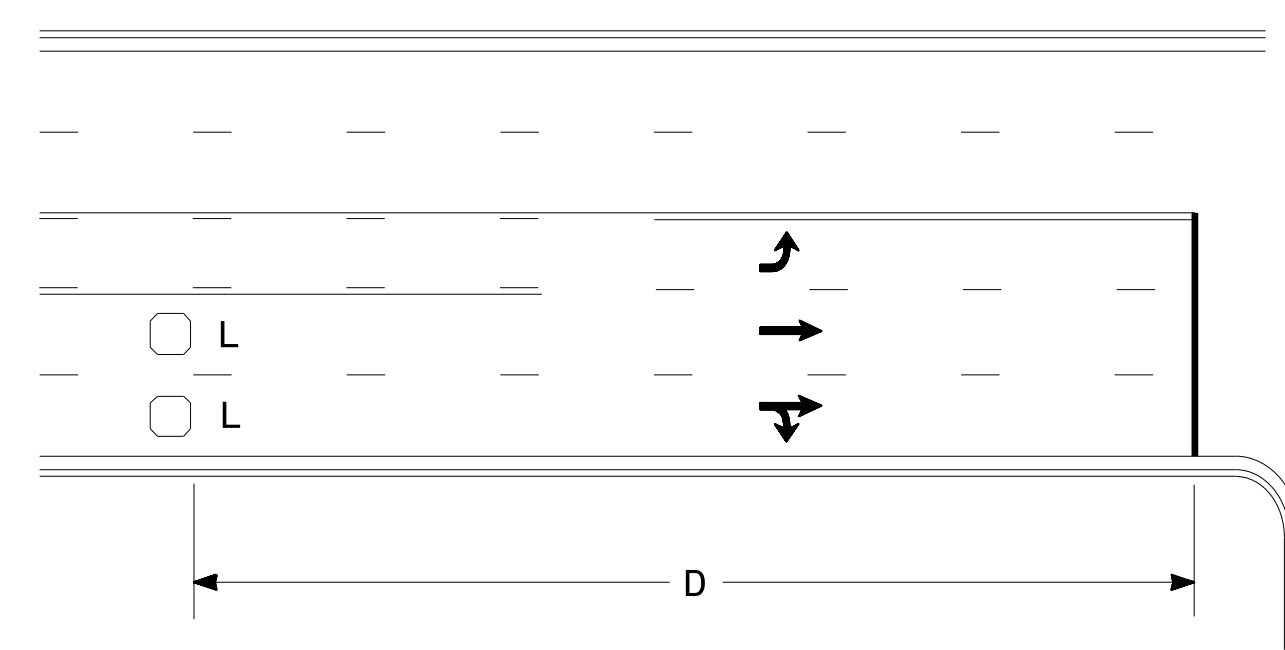

Speed Limit mph	D ft
40	250
45	300
50	355
55	420

L = 6ft X 6ft
Wired in series for TS1
Controllers
Wired separately for TS2,
170, and 2070L Controllers

Volume Density Operation

OR

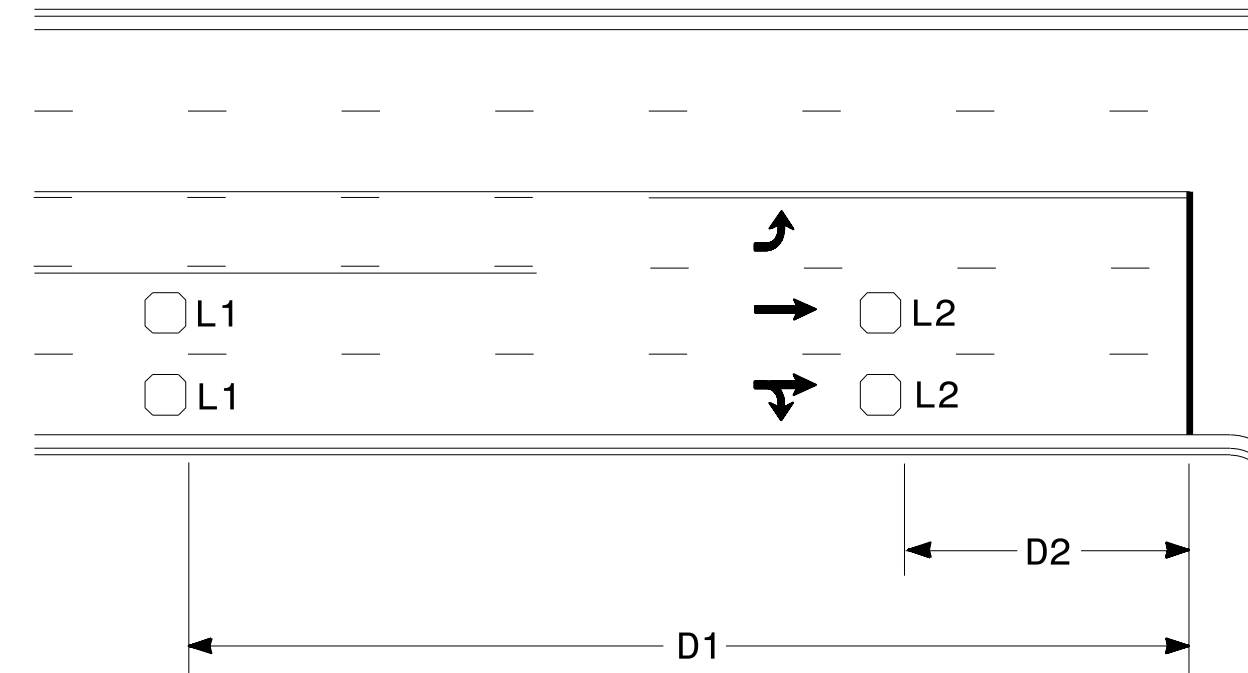

Speed Limit mph	D1 ft	D2 ft
40	250	80
45	300	90
50	355	100
55	420	110

L1 = 6ft X 6ft
Wired in series
L2 = 6ft X 6ft
Wired in series

"Stretch" Operation

Low Speed Detection (≤35 mph)

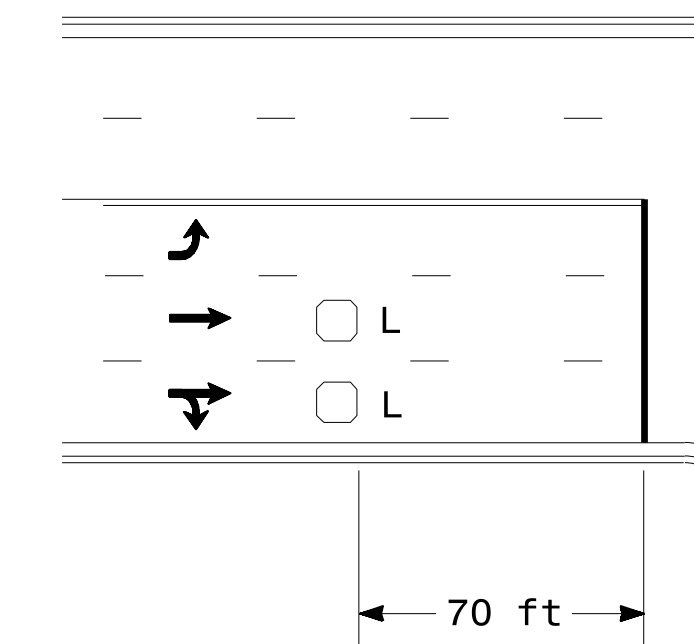

L = 6ft X 6ft
Wired in series

OR

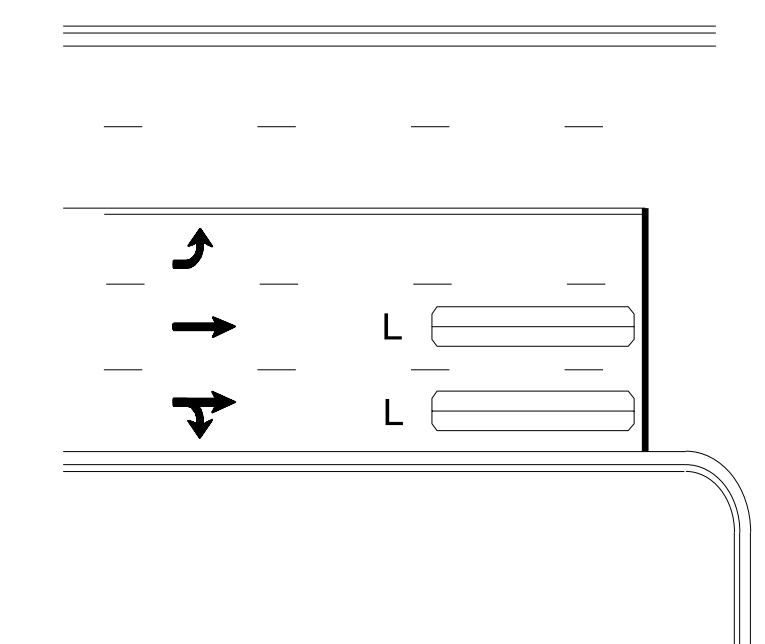

L = 6ft X 40ft
Quadrupole loop, wired separately

Left Turn Lane Detection

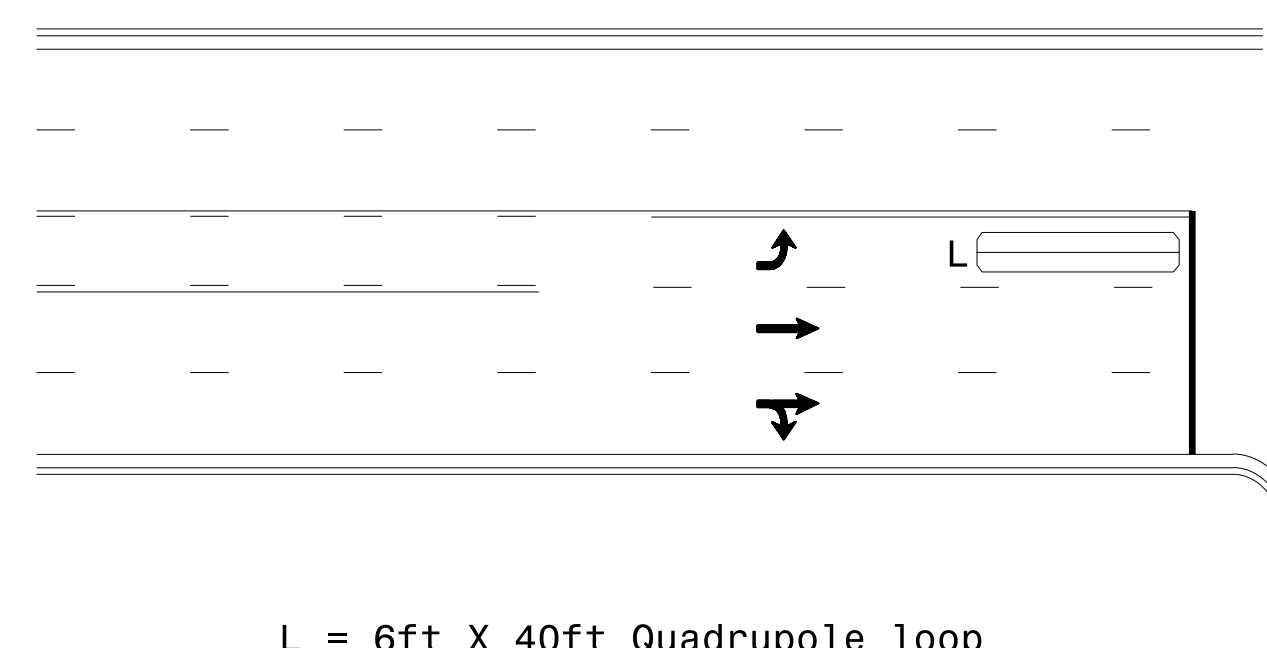

L = 6ft X 40ft Quadrupole loop

Presence Loop Detection

OR

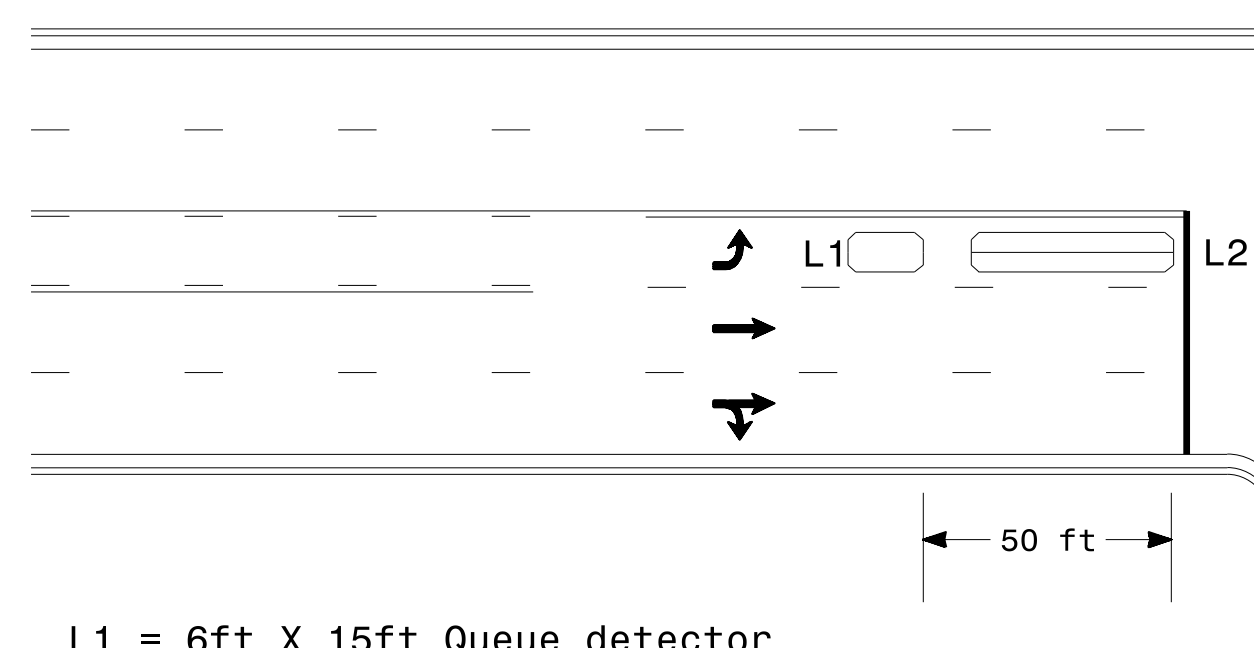

L1 = 6ft X 15ft Queue detector
L2 = 6ft X 40ft Quadrupole loop

Queue Loop Detection

Right Turn Lane Detection

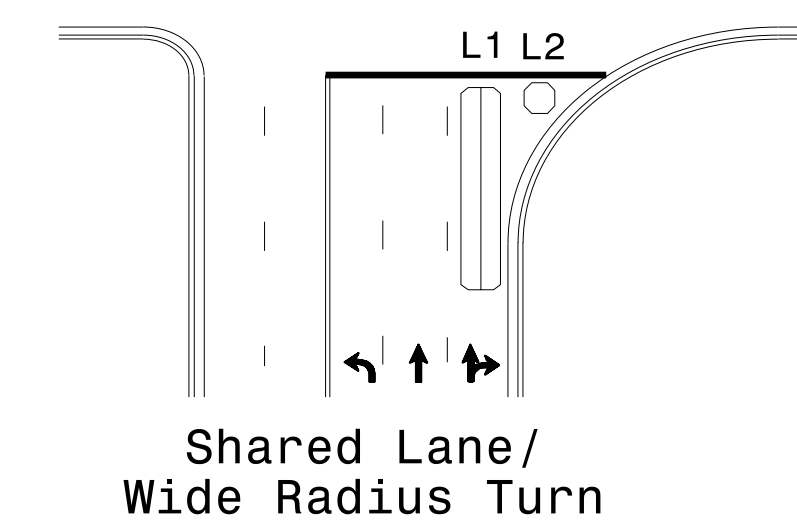

Shared Lane/
Wide Radius Turn

L1 = 6ft X 40ft Quadrupole loop
L2 = 6ft X 6ft [Minimum] Presence loop
Wired separately

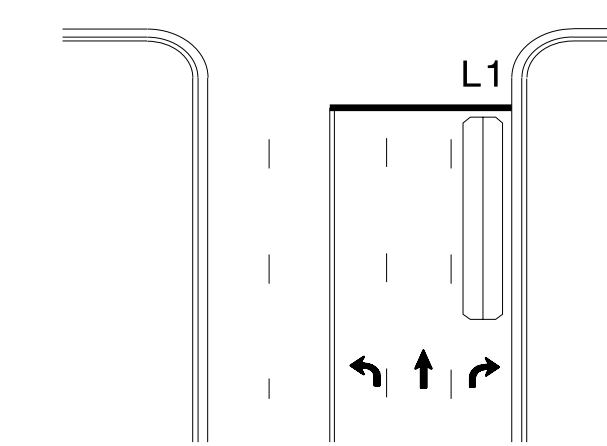

Standard Turn

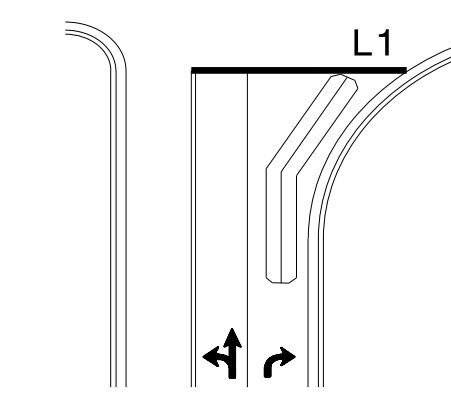

Wide Radius Turn

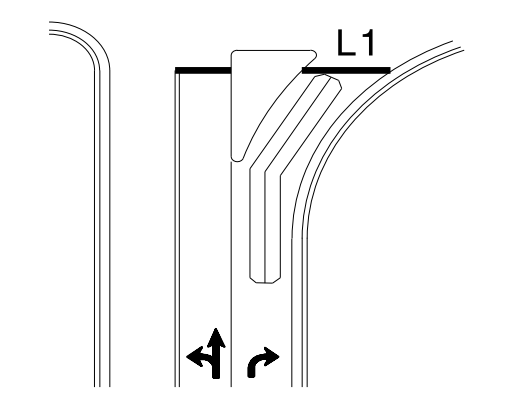

Channelized Turn

Side Street Detection

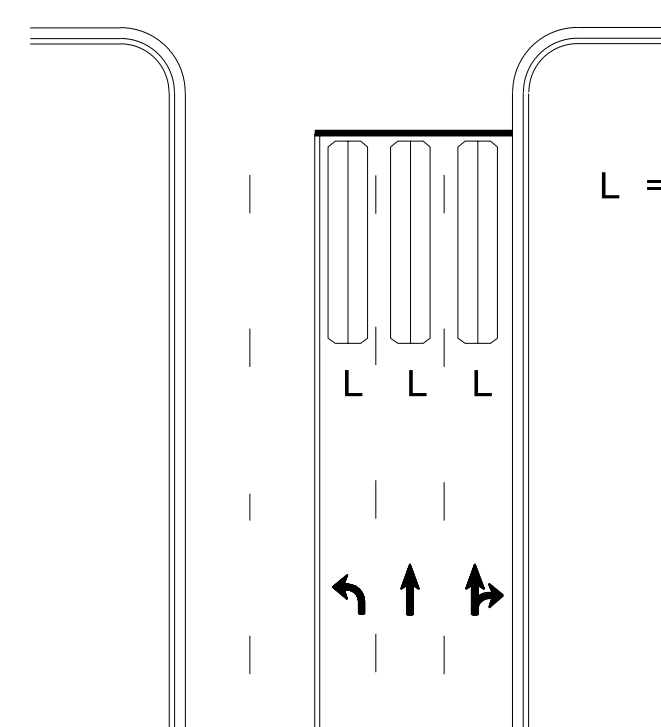

L = 6ft X 40ft
Quadrupole loop
Wired to separate
detectors/channels

Presence Loop Placement at Stop Lines

Locate loop slightly
behind leading
edge of stop line

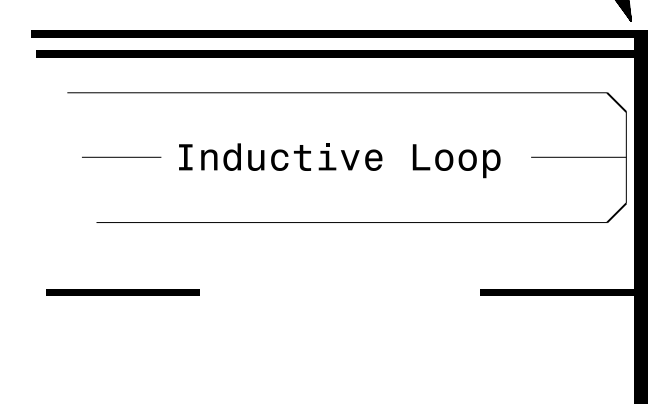

Note:

- Loop may be located in advance of stop line under any of the following conditions:
- 1) stop line is greater than 15' from edge of intersecting roadway
 - 2) loop detects a permissive or protected/permissive left turn
 - 3) for an exclusive right turn lane

Recommended Number of Turns

Single 6' X 6' loop
(when wired separately):

Length of Lead-in ft	Number of Turns
< 250	3
250-375	4
375-525	5
> 525	6

Quadrupole loops: Use 2-4-2 turns

6' X 15' Loops:

- Lead-in < 150', use 2 turns
- Lead-in > 150', use 3 turns

<p>Prepared In the Offices of: TRANSPORTATION MOBILITY AND SAFETY SOLUTIONS, INC. SIGNAL DESIGN SECTION 750 N. Greenfield Pkwy, Garner, NC 27529</p>	<p>Typical Signal Loop Locations</p>		<p>SEAL NORTH CAROLINA PROFESSIONAL ENGINEER PAMELA L. ALEXANDER 23489</p>
	<p>PLAN DATE: January 2015</p>	<p>REVIEWED BY: JPG</p>	
<p>PREPARED BY: PLA</p>	<p>REVIEWED BY:</p>	<p>REVISIONS</p>	<p>INIT. DATE</p>
<p>SIG. INVENTORY NO.</p>			<p>1/30/2015</p>